

BY11600

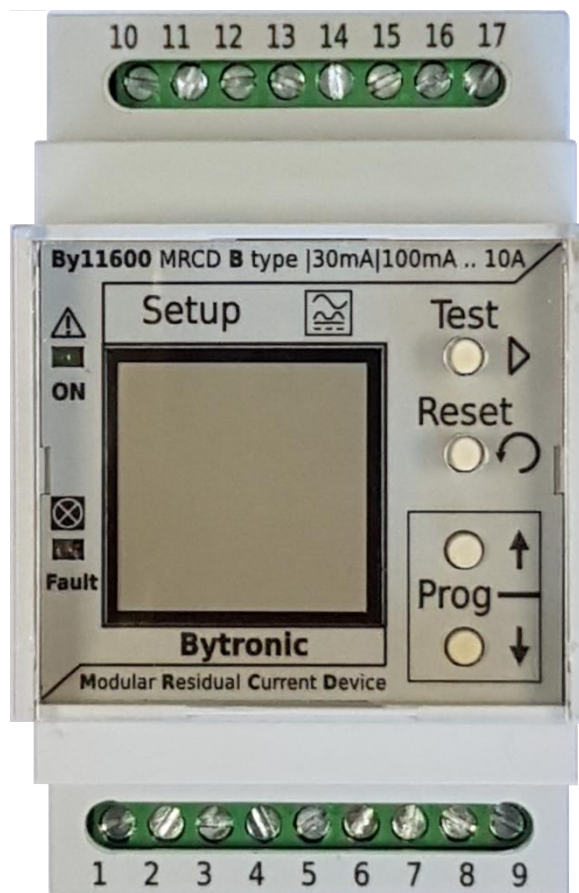

Earth leakage relay type B

(BY11600_M2_V1)

**(IF NOT DONE IN BYTRONIC) BEFORE INSTALLATION,
PERFORM THE C.T. PAIRING IN [CHAPTER 9](#) !**

This documentation is the exclusive property of:

Bytronic Srl - Via Como 55 - 21050 Cairate (VA) - ITALY.









It cannot be copied, modified or distributed, even partially, in any way and by any means, except with the explicit consent of the Owner.

The information and technical data contained in this documentation are subject to Copyright and intended exclusively and exclusively for Persons and / or Companies to whom they are expressly granted with restrictions on use.

Bytronic reserves the right to modify the specifications given without notice, at any time, according to the evolution of materials, technologies and production needs.

Bytronic is not responsible in any way for the consequences caused by the lawful or illegal use of the content of this document, whether due to inaccuracies, errors, incorrect interpretations or other.

No responsibility can be attributed to Bytronic Srl regarding any possible damage to things or persons deriving from any use of the described equipment. Its suitability, field of application and type of installation must be assessed by the user, who is obliged to comply with all the safety regulations in force and adopt all suitable solutions to avoid any damage deriving from the use of the equipment, assuming its total responsibility.

	<p>WARNING! It is mandatory to have the product installed by a qualified electrician, according to the safety regulations in force.</p>
	<p>This product is intended to be installed inside a switchboard or protection box, protected from external agents, chemicals and vapors. <u>All the prescriptions and specifications provided in this manual must be respected.</u> Under no circumstances should the electrical, thermal and / or mechanical limits indicated be exceeded, respectively the provisions for installation, use and maintenance. Refer to the 'Technical data' and the information in the various chapters.</p>
	<p>It is forbidden for any reason to open the casing of the product and / or its accessories. Under no circumstances should you attempt to repair or modify the product and / or accessories. In the event of a breakdown, repair is only permitted at the factory when possible. Do not install or replace the product or accessories that present damage to the casing.</p>
	<p>Any operation on the electrical contacts of the product must be performed in the absolute absence of voltage. Disconnect voltage before opening the panel and starting any operation.</p>
	<p>Periodically subject the product to TEST with the appropriate button, on a monthly basis. Periodically, it is advisable to check visually that the casing of the product and accessories are intact and not compromised, for example, by any over-temperatures that may have been generated inside the switchboard or by the wiring due to high currents.</p>
	<p>The transparent front should only be cleaned with a soft cloth and, if necessary, with water-based detergent. Never use solvents, alcohol or abrasive cloths.</p>
	<p>The product is NOT suitable for use in explosive areas and in any case in the presence of flammable substances even if occasionally or accidentally present.</p>
	<p>Do not dispose of this product together with other unsorted solid waste. It must be disposed of in accordance with the regulations for the recycling of electronic components.</p>

Failure to comply with these provisions relieves Bytronic Srl of any liability and causes the forfeiture of any form of guarantee.

SUMMARY

1	REFERENCES	1.4
2	GENERALITY	2.1
3	CONNECTIONS AND SYSTEM REQUIREMENTS.....	3.2
3.1	GENERAL SCHEME	3.2
3.2	CHOICE OF DETECTION DEVICE (TORB).....	3.3
3.3	PLANTING REQUIREMENTS	3.3
3.3.1	<i>Short circuit and overload protection</i>	3.3
3.3.2	<i>Auxiliary power protection</i>	3.3
3.3.3	<i>Connection and positioning of the detection device</i>	3.3
3.3.4	<i>Passage of conductors in the detection device</i>	3.6
3.3.5	<i>Processing device positioning (MRCD)</i>	3.7
3.3.6	<i>Connections to MRCD terminals (general)</i>	3.7
3.3.7	<i>Connection of the Failure output</i>	3.7
3.3.8	<i>Connection of the Alarm output</i>	3.7
3.3.9	<i>Connection of the Reset input remotely</i>	3.8
3.3.10	<i>Use of the Data Port</i>	3.8
4	PRINCIPLE OF OPERATION.....	4.1
5	OPERATION.....	5.1
5.1	FRONT PANEL	5.2
5.2	MEASUREMENT PAGE DISPLAY.....	5.3
5.2.1	<i>High Resolution Measurements (only in Instant mode, 0.03A)</i>	5.4
6	OPERATING CONDITIONS.....	6.1
6.1	GENERALITY	6.1
6.2	ALARM CONDITIONS	6.1
6.2.1	<i>Alarm condition storage (Memo Alarm = On)</i>	6.3
6.3	FAULT CONDITIONS.....	6.4
6.3.1	<i>Intervention times</i>	6.5
6.4	TEST EXECUTION	6.6
6.4.1	<i>Effect of the Test on the Alarm output</i>	6.7
6.5	RESET	6.7
7	OPERATION OF THE UP AND DOWN BUTTONS.....	7.1
7.1	'UP' BUTTON FUNCTIONS.....	7.1
7.1.1	<i>Selection of the tripping differential current ($I_{\Delta n}$)</i>	7.1
7.1.2	<i>Access to programming of operating parameters</i>	7.1
7.1.3	<i>Regulation functions in programming the operating parameters</i>	7.1
7.1.4	<i>Execution of the 'CT recognition procedure'</i>	7.1
7.2	FUNCTIONS OF THE 'DOWN' KEY	7.2
7.2.1	<i>Selection of downtime (Δt)</i>	7.2
7.2.2	<i>Regulation functions in programming the operating parameters</i>	7.2
8	OPERATING PARAMETERS.....	8.1
8.1	LIST OF OPERATING PARAMETERS.....	8.3
9	CT RECOGNITION PROCEDURE	9.1
10	RESIDUAL CURRENT MONITORING DURING INSTALLATION OR TESTING	10.1
11	TECHNICAL DATA	11.1

1 REFERENCES

This manual is in the following update state:

- File name:..... Manual BY11600_M2_EN_12.docx
- Revision:..... 12
- Date:..... 26.09.2023

The content refers to the firmware version 02.01.02 and later.



THE IMAGES CONTAINED IN THIS DOCUMENTATION ARE FOR APPROXIMATE PURPOSE AND COULD BE DIFFERENT FROM THE REAL ONES.

2 Generality

The BY11600 is a separate type B residual current protection (and monitoring) device (**MRCD**), according to **Annex M** of the European standard **CEI EN 60947-2: 2019-03**, identical to the international standard **IEC 60947-2: 2016 -06 / COR1: 2016-11**.

It is built in a sealable container for 3-module DIN 46277 (EN 50022) bar, with protection of the adjustments by means of a transparent door, with access to the 2 operating buttons (Test and Reset) with a appropriate tool.

It is classified as MRCD with voltage source, at nominal voltage of 230 Vac 50/60 Hz, *but it can be used as RCM (Residual Current Monitor) when no protection function is required.*

It can function either a non-delayed or a delayed device, according to the requirements of the standard.

It is designed for control on a three-phase network at 400V 50/60 Hz but also single-phase, and can work (**ONLY as RCM, never as MRCD**) for frequencies greater than 400Hz (*up to 600Hz in measurement class, at maximum at 1kHz with reduction of the measure of about 30%*). *In the nominal operating range (50 / 60Hz) the sensitivity up to 1kHz allows interventions in the presence of harmonics or in distorted conditions, being the TRMS measurement.*

It uses a separate detection device (Current Transformer, **CT**) Bytronic of the **TORB series**, to be chosen according to the use among 7 models, with internal diameter between 35 and 240mm, *model for high voltages.*

The BY11600 is able to recognize which detection device it is connected to, thanks to the "[CT recognition procedure](#)", described in detail below.

Overall, the BY11600 has 8 step current adjustments (0.03, 0.1, 0.3, 0.5, 1, 3, 5 and 10A), one of which is instantaneous (0.03A) and the other 7 delayed, with 9 non-operating times adjustable in steps (0.1, 0.2, 0.3, 0.4, 0.5, 0.75, 1, 5 and 10 s).

On the basis of the CT used, only the current ranges that it is able to manage are made available.

For any selected current range, *tripping is guaranteed according to the specifications of the standard for an alternating residual current greater than 10 times the nominal selected ($I_{\Delta n}$) and more than 20 times for the continuous residual current, at the nominal frequency (50/60 Hz), keeping the set non-intervention time (Δt) when the delayed mode is selected. Intervention is always guaranteed up to sensor saturation and in any case certainly for a differential current I_{Δ} of at least $6 I_n$, shortening the non-tripping time to 1 second if set greater than 1s.*

The BY11600 has 2 changeover relay outputs of 230V 10A AC1 as standard, one for 'fault' for controlling suitable interruption devices or for monitoring tripping, and the other for 'alarm', fully programmable from the 'user, for example to monitor the residual currents of 6mA.

It also has a high contrast 128x128 pixel 'ink look' graphic display, on which settings and measurements are shown in detail, as well as operating states and alarm / fault conditions.

During normal operation, ALL the information relating to measurements (I_{rms} , I_{ac} and I_{dc}), fault output adjustments and type of detection device are collected in the single measurement page which is always visible. No button action is required to view more information. The option to test or reset is also possible. In case of intervention, the display page changes automatically to show the diagnostic data. On reset the main page reappears. All this, after installation, allows you to use the instrument even after a long time without the aid of the instruction manual.

The particular technology with which the BY11600 has been made makes it practically immune to magnetic fields external to the detection device (eg Earth's magnetic field) and also does not require any demagnetization procedure to be carried out by the CT. In addition, the TORB series devices are practically insensitive to temperature variations within the intended operating range.

The alarm / fault conditions signaled on the display are also indicated by the 2 LEDs with which it is equipped, one red with high brightness (Fault) and one green for the indication of ON and alarm.

It is also possible to perform the 'Reset' remotely on the opto-isolated input as standard.

Using the BY11800 additional module, the BY11600 can be remotely monitored on an optoisolated high speed RS485 network, with MODBUS RTU or ASCII MODBUS automatic recognition protocol.

More details in the following sections.

3 Connections and system requirements

3.1 General scheme

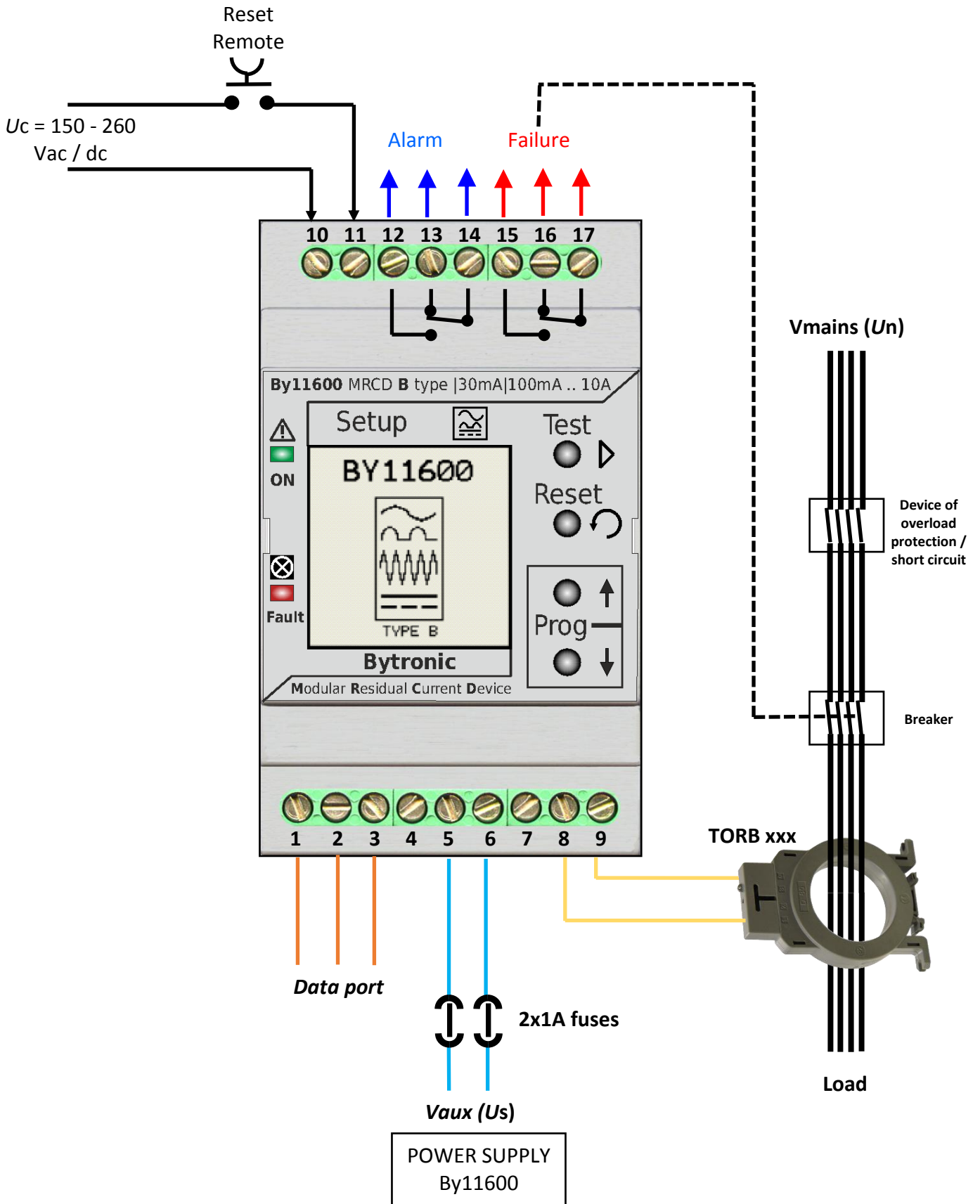

3.2 Choice of detection device (TORB)

	<p>The detection device must NECESSARILY be of Bytronic manufacture and belong to the "TORBxxx" family.</p> <p>Bytronic declines any responsibility deriving from the use of non-original devices.</p>
---	---

The number represented after the prefix "TORB" represents the internal diameter of the hole for the passage of the cables. The limits of use of the various devices are summarized in the table:

Template	I_n (A)	Operating limit I_{max} (A)	$I_{nno} = 6 I_n$ (A)	Max section/phase mmq (3F + N)	Minimum Threshold $I_{\Delta n}$ (A)	Maximum Threshold $I_{\Delta n}$ (A)
TORB 35	60	170	360	16	0,03	3
TORB 60	75	200	450	25	0,03	3
TORB 80	140	330	840	70	0,03	3
TORB 110	200	450	1200	100	0,1 ⁽¹⁾	5
TORB 160	275	600	1650	150	0,3 ⁽¹⁾⁽²⁾	10
TORB 210	350	720	2100	2x185	0,3 ⁽¹⁾⁽²⁾	10
TORB240HV	750	1500	4500	Bars/Cables ⁽³⁾	0,3 ⁽¹⁾⁽²⁾	10

Table 1: Choice of detection device

Note (1): The 0.03A range is not available when combining this model.

Note (2): The minimum selectable range is 0.1A but, only at this range, the measurement error is not guaranteed (can be greater, max. +/- 10%), and the non-intervention at 6In (I_{nno}) is not guaranteed.

Note (3): The total area occupied by the bars or cables and their insulation must be less than 22000mmq.

Use a sensing device with an internal area at least twice that of the total cross section of the cable or bundle of cables, including insulation distances.

	<p>All models can withstand the overload regime determined by the non-tripping limit current (I_{nno}), in the absence of a differential current I_{Δ}. However, in order to guarantee intervention in all conditions in the presence of I_{Δ}, the following system prescriptions must be respected, especially for the 'Passage of conductors in the detection device' (3.3.4).</p>
---	---

3.3 Planting requirements

3.3.1 Short circuit and overload protection

An upstream protection device against overloads and short-circuit currents must be provided upstream.

The protection device must have a breaking capacity at least equal to the short circuit current presumed at the point of installation.

3.3.2 Auxiliary power protection

The connection of the auxiliary power supply (U_s) must take place via 1A protection fuses.

3.3.3 Connection and positioning of the detection device

The type of connection of the detection device is all the more important as:

- the currents to be detected are low and for which it is required to intervene and / or
- the installation environment is hostile, due to the presence of strong radio frequency electromagnetic fields (e.g. repeaters, radio links, transmitters, etc.) or due to the presence in the system of elements which are in turn disturbing elements such as inverters, phase cutting, tripping of remote control switches etc. etc., and / or
- the connection distance between the detection device and the MRCD is long

Clearly it would be desirable that ALL precautions be taken to avoid untimely interventions, which can cause significant economic losses due to the unnecessary detachment of the load (system restart, stop important processes, etc ...).

However, adopting all the precautions beforehand even where objectively it is not necessary, means facing higher plant costs which in small plants can be significant.

It is therefore advisable to follow an 'increasing guarantees' scheme, establishing what is necessary according to the [Table 2](#) and gradually taking more targeted (and expensive) measures if problems arise with the system built.





	Twisted cable	Shielded cable with EMC hook	Additional EMC devices
Basic condition			
Radio frequency EM fields	-	• (always)	[1]
Passage of strong impulse currents in the switchboard / load	-	• (always)	[1]
Use for $I_{\Delta n} = 0.03A$	-	• (always)	[2]
$I_{\Delta n} \geq 0.1A$, distance <50cm	• (allowed)	• (optional)	-
$I_{\Delta n} \geq 0.1A$, distance between 50cm and 3mt	-	• (always)	[2]
$I_{\Delta n} \geq 0.1A$, distance between 3 and 10mt (maximum)	-	• (always)	[3]

Table 2: Choice of the type of basic connection to the detection device

Note [1]: The device is optional and when present, its nature is studied on a case by case basis

Note [2]: The device is strongly recommended and in any case when present, its nature is studied on a case by case basis

Note [3]: The device is mandatory and its nature is studied on a case-by-case basis

	<p>Regardless of the type of connection made, the following precautions must ALWAYS be taken:</p> <ol style="list-style-type: none"> 1. The sensor wiring must be SEPARATED from the other wiring in the panel (it must not be 'bundled' or put in the same sheaths with power, power or control cables). 2. The wiring must follow a path as far as possible away from cables and power devices 3. The CT MUST be installed as far as possible from power and control devices (remote switches, electromagnets, inverters, transformers, drives, permanent magnets, etc., etc. ..). <p>Being by its nature and operation a device sensitive to both continuous and alternating magnetic fields, it is absolutely necessary to avoid that it can 'receive' electromagnetic signals from nearby devices.</p>
---	--

In detail, the types of connection and the recommended methods are as follows:

TYPE OF CONNECTION / ADDITIONAL DEVICE	DESCRIPTION
	<p>Twisted cable. 2 standard electric wires, at least 0.5 sq. Mm in section, which must be carefully intertwined (twisting) with each other. <u>It is not suitable for currents <0.1A and for distances greater than 50cm.</u> It is the most economical solution but it exposes to untimely tripping risks in the presence of EMC disturbances.</p>
	<p>Shielded cable with EMC fixing. The maximum recommended length for connection with the detection device is 3m. This is the solution to always adopt when you can. <u>Connections over 3mt for differential currents <0.1A (0.03A) are always STRONGLY RECOMMENDED. The risk of untimely interventions, despite the precautions and precautions, are almost inevitable.</u> We always recommend good quality cable, for example type BELDEN 9841 or equivalent cable (available on request). The shielding must be connected to the DIN bar (which in turn must be connected to the switchboard and to the earth) but ONLY near the connection terminals of the BY11600 (not at other points), using special metal clamps. Do not connect the shield in other ways (e.g. with welded wire). There is a special connection of the shielding to the DIN bar, such as this type</p>   <p>This hook (for BELDEN 9841 cable or equivalent) is also available on request.</p>
	<p>Additional EMC devices ALWAYS apply for connections > 3mt. They can be of various kinds, and consist of elements such as ferrites or special shielded cables with reinforced shielding, also in combination with each other. Their use in particular cases may also be necessary for connections of less than 3m in length, in particularly hostile environmental conditions. The appropriate application of these devices requires the intervention of our Technical Assistance service, because they are highly dependent on the type of system and specific environmental conditions.</p>

Regardless of the type of cables used, the connection on the detection device must take place with 6.3mm Female Faston, to be crimped on each of the 2 conductors and to be inserted indifferently (without polarity) in the TORBxxx contacts.

When using shielded cable:

- DO NOT connect the shield near the TORB detection device (isolate it), e

- From the BY11600 side, the 2 wires to be inserted in the respective terminals must be stripped (7mm).

3.3.4 Passage of conductors in the detection device

The following requirements must be observed:

- Use a detection device having an internal diameter (d2) at least double the diameter of the cable or cable bundle (d1), and in any case in accordance with the [Table 1](#);**

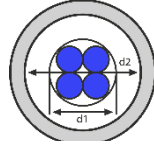

- Keep the conductors together, as close as possible to the center of the sensing device. A conductor closer than the others to the edge of the cable passage can determine the saturation of the ferromagnetic core with consequent non-linear, incorrect or even absent response;**

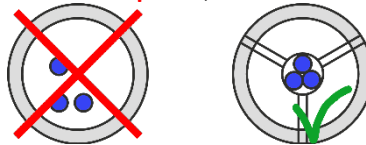

- To help adequately protect the detection device from any mechanical damage due to the repulsive effect of the conductors as a result of any short-circuit currents (single-phase) not intercepted in time by the short-circuit protection device, mechanically block the cable bundle immediately upstream and downstream (e.g. with clamps, tapes or high-resistance clamps). The lock must be able to withstand a force F in Newton of at least:

$$F = \frac{2 * 10^{-7} * I_{cc}^2 * L}{d}$$

Where is it:

I_{cc} is the effective value of the presumed short-circuit current at the CT, in Ampere;

L is the distance between the upstream and downstream blockages in meters;

d is the distance between the conductors in meters;

depending on the type of system and the direction and phase of the currents in each conductor.

- The bundle of cables that passes through the detection device must not have bends at a distance of less than 2 times the diameter in both directions;

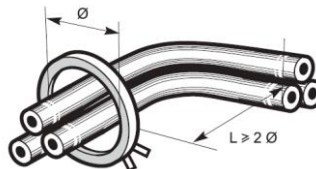

- In extremely critical cases, install a ferromagnetic sleeve arranged around the conductors inside the detection device with diameter D = internal diameter and length L = 2D, to make uniform the distribution of the magnetic field, avoiding untimely intervention by high inrush currents ;

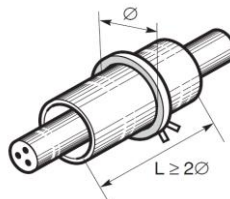

- The detection device must be crossed in the same direction by all the active conductors of the line, including the neutral (when present). The neutral must NOT be earthed downstream of the detection device;
- In the event that the protected power line has a metal armature that must be earthed, this must NOT cross the CT. If it is grounded and crosses the CT, it must be passed back to the CT to cancel any fault current that may travel through it.

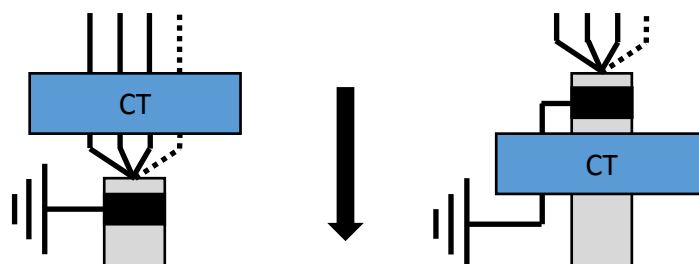

3.3.5 Processing device positioning (MRCD)

The BY11600 (MRCD) must be installed on DIN 46277 rail (omega bar), POSSIBLY at a distance $\geq 50\text{mm}$ from other equipment or modules installed nearby, which could interfere electromagnetically.

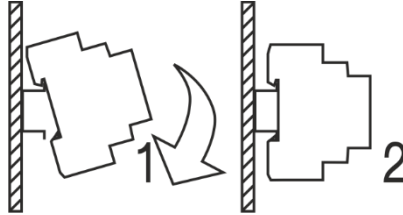

This prescription becomes mandatory for precautionary purposes if, if not respected, anomalies of measurement or apparently unwanted interventions occur.

3.3.6 Connections to MRCD terminals (general)

The terminals of the MRCD accept cables with a maximum section of 2.5mm^2 and have a maximum current capacity of 10 A. The maximum (recommended) stripping length of the cable is 7mm and the maximum tightening torque is 0.5 nm

3.3.7 Connection of the Failure output

	<p>In the event that the MRCD is used as a protective device:</p> <ol style="list-style-type: none"> 1. <u>ONLY the "Fault" output can and must properly control a suitable disconnecting device (disconnecter);</u> 2. <u>The "Fault" output cannot be used directly as an interruption device</u>
--	---

The BY11600 is able to control both 'current launch' and 'undervoltage' release devices, because the "Fault" output can be programmed NO or NC at rest and the presence of the changeover contact makes it flexible use.

	<p>When using the MRCD at the current value $I_{\Delta n} = 0.03\text{ A}$, it becomes a NON delayed type and it must be combined with a cut-off device of an appropriate size for the system, whose overall opening time is less than 0.015 s, in order to guarantee compliance with the intervention according to Table B.1 of the Standard.</p>
--	---

Otherwise, when the MRCD is delayed, a convenient switch / contactor can be used, according to the overall intervention time desired (maximum MRCD intervention time declared + intervention time of the chosen device; see '[Technical features](#)').

The section of the connection cables with the release device must be suitable with respect to its absorption, and in any case between 1 and 2.5mm^2 .

3.3.8 Connection of the Alarm output

It can be used flexibly according to its programming, for diagnostic, warning or secondary purposes ("monitor").

	<p><u>The "Alarm" output MUST NOT BE USED FOR PROTECTION.</u> <u>It MUST NOT COMMAND THE INTERRUPTION DEVICE.</u></p>
--	---

It has the same electrical characteristics as the Failure output and also the same prescriptions as regards the connection to a load.

3.3.9 Connection of the Reset input remotely

The MRCD has an optoisolated input which when powered with a voltage between 150 and 260 V indifferently ac or dc, performs the same function as the 'Reset' button on the front of the instrument.

There are no particular recommendations regarding this link.

3.3.10 Use of the Data Port

The data port is used for remote monitoring of the device.

It must be connected to the 1 DIN module for serial communications BY11800, isolated at 3kV, which allows the status and measurements of the BY11600 to be put on the MODBUS network (RTU or ASCII), in order to monitor a system with multiple protected areas.

Through MODBUS communication, for each BY11600 + BY11800 connected to the network, it is possible to know:

- Device data (version-revision)
- The type of TORB sensor connected
- The settings (programming)
- Operating conditions (Sensitivity and delay)
- The measurements of the current RMS, AC and DC components, expressed in%
- The Alarm and Fault states, with type (exceeding I, sensor fault, Test etc ..) and intervention values%

The connection and operation details are contained in the BY11800 product documentation.



DO NOT CONNECT ANY DEVICE OTHER THAN BY11800 TO THE DATA PORT.

4 Principle of operation

The instrument is a type B differential relay **delayed and instantaneous** with separate detection device, which meets the specifications of the **Standard CEI EN 60947-2: 2019-03 Annex M**.

It has a sensitivity of differential current $I_{\Delta n}$ adjustable in steps between 30mA and 10A, divided as follows:

0.03 - 0.1 - 0.3 - 0.5 - 1 - 3 - 5 and 10A.

In this documentation, when we speak of "current measurement", it is always intended as DIFFERENTIAL current (I_{Δ}).

The 0.03 A rating classifies the instrument as suitable for additional protection from direct contacts, i.e. without delay and with intervention times in accordance with Table B.1 of the Standard, **provided it is used with a suitable detection device (see Table 1)** with equally suitable **interruption device** suitably connected to the 'Fault' output.

The other current flows classify it as a delayed type device suitable for protection from indirect contacts, giving the possibility to adjust the non-operation time Δt in steps from a minimum of 0.1 to a maximum of 10 s, divided as follows:

0.1 - 0.2 - 0.3 - 0.4 - 0.5 - 0.75 - 1 - 5 and 10 s

This is the time within which the MRCD DEFINITELY DOES NOT intervene in the presence of a DOUBLE current with respect to the selected one ($2 I_{\Delta n}$).

The instrument is suitable for fire protection in TT TN systems, by regulating $I_{\Delta n} \leq 0.3A$ for the terminal circuits, and $\leq 1A$ for the distribution circuits (IEC 60364-4-482).

Normally the instrument is supplied from the factory already coupled to a "TORBxxx" type detection device chosen by the customer when ordering.

The instrument is in fact able to recognize the type of sensor connected and in order to use it with a different type sensor (different diameter) it is always necessary to use an auto-recognition procedure that can be performed in the field. Without carrying out the procedure, the instrument will go into Fault indicating the anomaly.

The procedure is also necessary by replacing the sensor with one of the same type, to calibrate any small construction differences that could cause excessive measurement errors.

Current measurements are performed in true RMS (TRMS) and also in separate components (ac and dc).

The intervention thresholds of the MRCD are 6, to which the 2 relay outputs correspond respectively:

- "Fault" threshold (rms, ac and dc) e
- "Alarm" threshold (rms ac and dc)

The one to be used for protection is the "Fault" output.

It is only partially programmable, compared to the Alarm one which is totally programmable but can only be used for reporting purposes and NEVER for protection. The differences are as follows:

Programmable function	"Fault" output	"Alarm" output
Relay contact polarity	YES (NOT C)	YES (NOT C)
Current threshold (rms)	NO ($0.85 I_{\Delta n}$)	YES ($0 - 2 I_{\Delta n}$, 0 = Excluded)
Current threshold (ac)	NO ($0.75 I_{\Delta n}$)	YES ($0 - 2 I_{\Delta n}$, 0 = Excluded)
Current threshold (dc)	NO ($1.5 I_{\Delta n}$)	YES ($0 - 2 I_{\Delta n}$, 0 = Excluded)
Intervention delay for rms, ac and dc thresholds	NO in the non-delayed (INST) mode, YES by selection Δt in the delayed mode	YES ($0 - 10.0$ s)
Threshold intervention memorization	NO (always memorized)	YES (ON - OFF)

When we speak of "threshold", that of "Fault" will always be implied, unless specified as "Alarm".

In conditions of differential current in PURE sinusoidal regime, the BY11600 non-intervention threshold is $0.75 I_{\Delta n}$ for the alternating component.

For the PURA continuous component, on the other hand, it is $1.5 I_{\Delta n}$.

If both the ac and dc components are present, the non-intervention threshold is set at $0.85 I_{\Delta n}$ of the rms component.

In order to intervene, the differential current must remain above the rms, ac or dc component beyond any set non-operation time if in the delayed mode, otherwise immediately in the instantaneous mode.

The first of the valid conditions will trigger the Fault relay.

The "Fault" condition cannot be restored until the differential current returns below all the intervention thresholds. Until this happens, the 'Reset' button and the relative 'Remote reset' input remain inactive.

5 operation

After correctly connecting the instrument as shown in the diagram, it is also necessary to check that it is correctly configured before powering the protected system, namely:

- The connected detection device (TA) must be the one with the diameter foreseen and previously recognized. If the CT has also been replaced in the system with one of the same type, the '[CT recognition procedure](#)' described in the relevant chapter.
- The value of $I_{\Delta n}$ and of Δt must be those desired. Set them as described in the chapter '[Operation of the UP and DOWN buttons](#)'.
- The polarity of the output relays must be the desired one. To see '[Operating parameters](#)'.
- The behavior of the Alarm output (if used) must be set as desired. To see '[Operating parameters](#)'.

When the system is running, to carry out the Test, press the Test button (corresponding to the letter T in the negative on the display) and then see operation in the section '[Test execution](#)'.

For explanations regarding the alarm conditions, fault conditions and their recovery, see the relative chapters '[Alarm conditions](#)', '[Fault conditions](#)' is '[Reset](#)'.

After installation and correct programming, the key protection door can be leaded through the adjacent side holes of the container. The functions of Test is Reset they will however be accessible by suitable means.

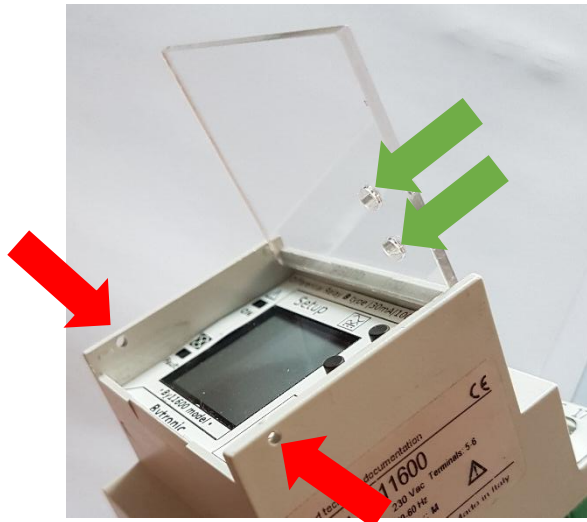

5.1 Front panel

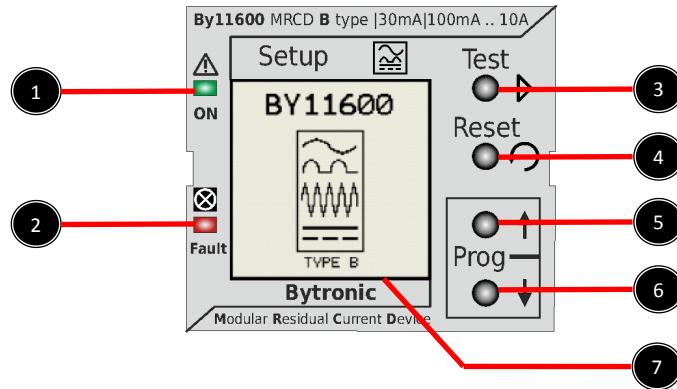

1	ON / ALARM led	ON FIXED = Indicates normal operating status ON FLASHING = Indicates Alarm relay output in ALARM status. To see ' Alarm conditions '.
2	FAULT LED	When lit steadily, the Fault relay output is in a FAULT state. To see ' Fault conditions '.
3	TEST button	It is accessible from the front of the instrument with the door closed, using a suitable tool (pen, screwdriver, etc.). See operation in section ' Test execution '.
4	RESET button	It is accessible from the front of the instrument with the door closed, using a suitable tool (pen, screwdriver, etc.). See operation in section ' Reset '.
5	'UP' button	It is accessible only with the door open. To see ' Functions of the UP button '.
6	'DOWN' button	It is accessible only with the door open. To see ' Functions of the DOWN key '.
7	Graphic display	View measures, states and messages. The one represented is the page of 'logo' displayed at power on, which disappears after 3 s. The indications displayed will be explained later.

5.2 Measurement page Display

The instrument, when it is in its standard operating mode, has a single measurement display page:

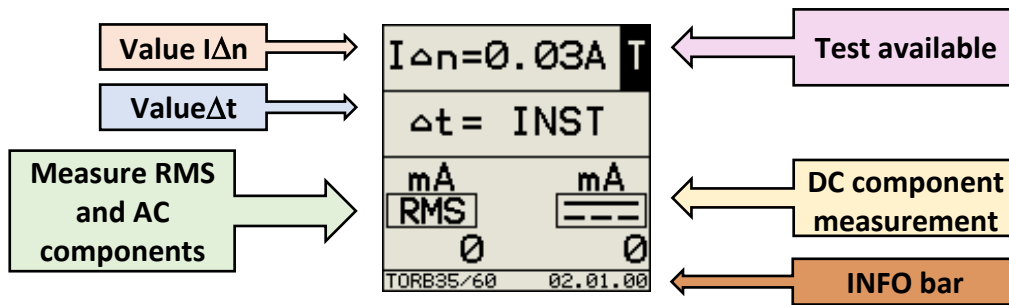

The displayed one is the page as per factory settings, in the absence of differential current.

The RMS measurement of the current and its AC component alternates approximately every 3 seconds:

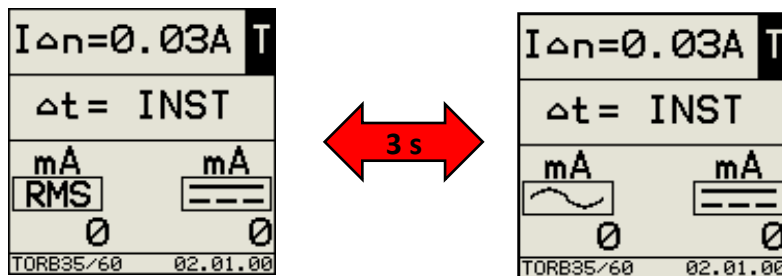

The 'INFO' bar contains the type of detection device associated on the left and firmware version information on the right.

CAUTION: this is the setting for protection against indirect and additional contact against direct contact ($I_{\Delta n} = 0.03A$). **This setting is NOT POSSIBLE** if TORB 110, TORB 160 or TORB 210 are used (the instrument does not admit 0.03 A selection).

In case of use with TORB 110, TORB 160 or TORB 210 the first factory page will be the following (ex. TORB 160):

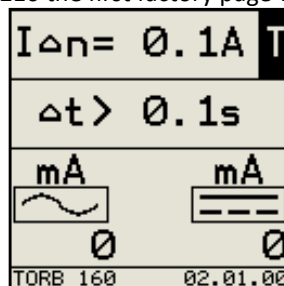

Remember also that with TORB160 and 210 it is possible to select the 0.1A range but there could be a greater measurement error of the DC component, which in any case does not exceed +/- 10%.

The "T" at the top right indicates that the "Test" button is enabled and that if pressed it will trigger the "Failure" output.

In the central part of the status bar, the information of the polarity (+) NC, with positive safety, of the Failure output can be present:

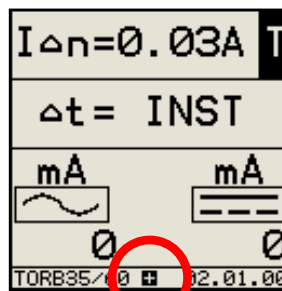

When the instrument is set up for protection against indirect contact ($I_{\Delta n} = 0.03 A$) no delay can be set.

Delay Δt is adjustable only if $I_{\Delta n} > 0.03 A$

An icon may appear in the display area between the two measurements, such as:

	<p>Pre-failure condition (flashing icon - flashing value)</p> <p>The continuous component threshold has been exceeded (the value on the display flashes) but we are within the non-operation time (10 s). If the condition remains beyond 10 s, the "Fault" intervention will take place. For more details, see 'Fault conditions'. If only the AC or RMS threshold is exceeded, the alternation of the display stops in favor of the value that is exceeding the threshold, keeping it displayed.</p>
	<p>Pre-alarm and alarm condition (flashing icon - flashing value)</p> <p><u>By default the alarm conditions are deactivated and this signal does not appear.</u></p> <p>When it appears, it means that an appropriate alarm level has been programmed which causes, in addition to the flashing of the icon and the value concerned, also the flashing (delayed) of the green ON / Alarm LED. The "Alarm" output is active only with a flashing green LED. For all the details, see 'Alarm conditions'.</p>

5.2.1 High Resolution Measurements (only in Instant mode, 0.03A)

It is possible, for diagnostic purposes such as the monitoring of residual direct currents, to activate the display of the measurements in 'High resolution' when the instrument is set for protection against indirect contact. This allows you to view the current values with a decimal but on the other hand the 'roll' that derives from it in the presence of small perturbations of the currents, could annoy you. For this reason the factory is set to 'Off'. To see '[Operating parameters](#)'.

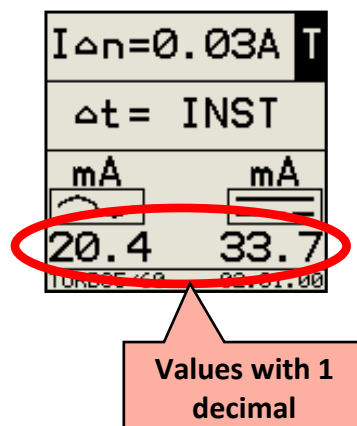

6 Operating conditions

6.1 Generality

Since the instrument is powered, it is IMMEDIATELY operational, regardless of what is shown on the display. The conditions that are the source of "Fault" (exceeding current thresholds, anomalies of the detection device) are monitored and processed immediately, in accordance with point M.8.3.4.3.

After the instrument has been commissioned, no verification or calibration procedure is required each time it is switched on.

The factory "Alarm" conditions are deactivated. If you want to use them, they must be properly set. Once set, they become operational symmetrically under the "Fault" conditions.

6.2 Alarm conditions

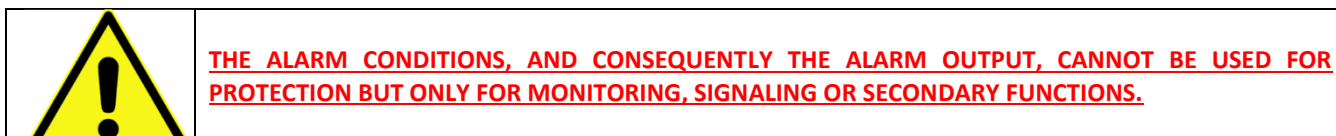

Unlike the Fault conditions which depend on the instantaneous values of the measurements, the Alarm conditions **depend** on the indications on the display and on the arbitrarily set delay time.

The measured values shown on the display represent the **average values** measured by the instrument and therefore are delayed with respect to the instantaneous values. The thresholds possibly set on these values cannot therefore be used for any reason as protection against indirect contacts nor as additional protection against direct contacts.

The alarm conditions can be set (or excluded) individually for the RMS value, for the AC component and for the DC component. The first of the conditions that is satisfied causes the relay to intervene, in the mode chosen with the other parameters.

The parameters that concern the setting of the alarm conditions are:

- **HiResDispl**
- **PolarAlarm**
- **ThRMS Alarm**
- **ThAC Alarm**
- **ThDC Alarm**
- **Δt RMS Alarm**
- **Δt AC Alarm**
- **Δt DC Alarm**
- **Memo Alarm**

The meaning of each parameter is described in the section '[List of operating parameters](#)'

Exceeding one or more alarm thresholds (rms, ac and / or dc) is indicated by the flashing alarm icon on the display among the three measurements, with the value(s) concerned flashing.

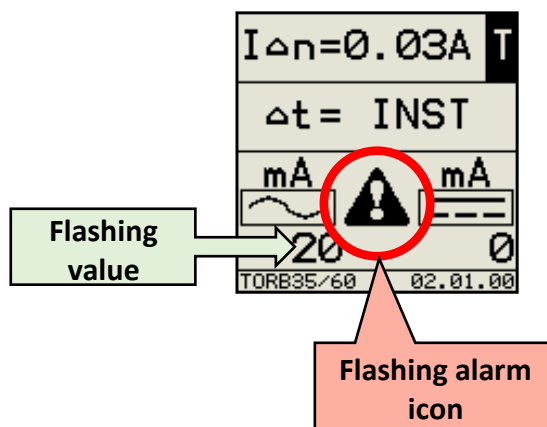

In the example it is assumed that the alarm threshold value of the alternating component (**ThAC Alarm**) has been set at a level lower than 66% with respect to the value of $I_{\Delta n}$.

The alternation of the AC / RMS measurement on the viewing of the AC value, the one that is exceeding the threshold is blocked).

The flashing of the icon and the value indicate the instantaneous exceeding of the threshold (pre-alarm condition) but not the intervention of the "Alarm" output, which occurs only when the relative delay time runs out (in the example, after the eventual time of **Δt AC Alarm** if set).

The "Alarm" output is active only when the green ON / Alarm LED flashes.

If the 'Memo Alarm' parameter is Off, the Alarm condition automatically disappears if the condition that caused it returns below its threshold value.

When the Alarm condition is present, it is affected by pressing the Test button when pressed.

To see ['Effect of the Test on the Alarm output'](#).

6.2.1 Alarm condition storage (Memo Alarm = On)

When the exceeding of the Alarm threshold is detected for one or more components, as already seen before, also in this case it happens that:

- the measurement value concerned flashes;
- flashing alarm icon appears.

From this moment, after the relative intervention delay time:

- the Alarm relay intervenes, signaled by the flashing of the ON / Alarm LED;
- the value of the measure concerned is 'fixed', allowing to 'memorize' only higher values if they are detected, so as to **always show the maximum value reached**. If the current drops, the display keeps the higher value.

Warning: the 'fixed' measurement stops being in real time.

The flashing value displayed will therefore be the maximum value reached by the component of the measured current since it was 'set' the first time.

The other measure continues to show the value in real time, unless it too exceeds its alarm threshold and goes to 'fix' when it exceeds its delay time, even if the Alarm output is already active.

In the case of the RMS and AC components, when a component is fixed, the display alternation stops. If the other component grows, the display will be updated accordingly.

To be able to 'memorize' the Alarm condition, it is necessary that the area of the display adjacent to the Reset button indicates 'R' in negative, that is, when all the RMS, AC and DC components fall below the relative threshold value.

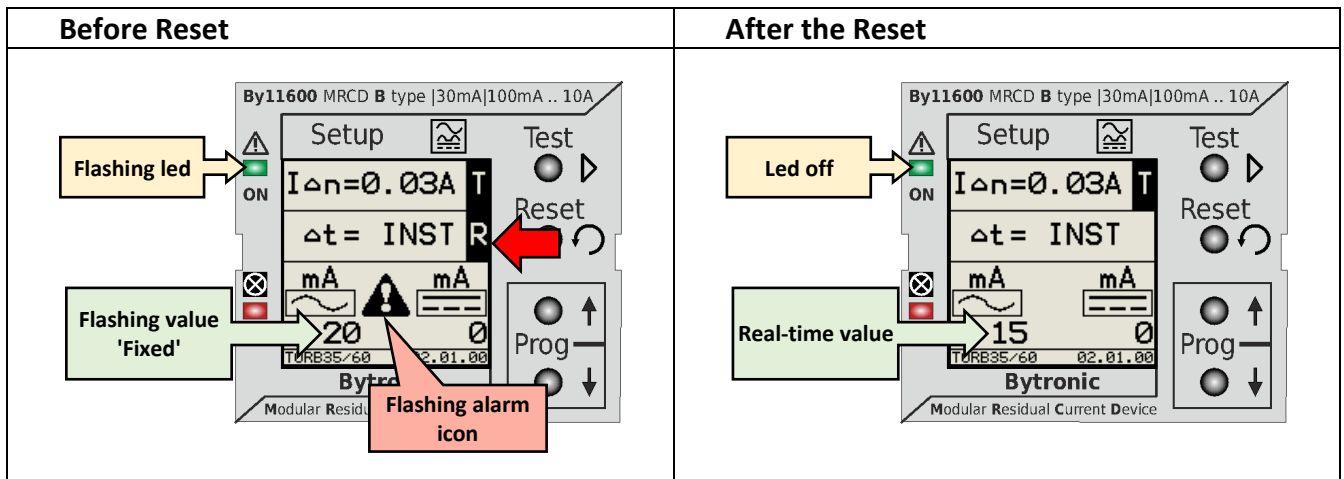

For further details, see paragraph ['Reset'](#).

6.3 Fault conditions



THE FAILURE CONDITIONS, AND CONSEQUENTLY THE FAILURE OUTPUT, ACT ON EXACT VALUES RECEIVED IN REAL TIME, INDEPENDENTLY OF THE VALUES ON THE DISPLAY.
The values on the display, although reliable, are only indicative and can in some cases provide partial indications, especially in the presence of large and rapid variations in the differential current.



When the use of the device is for protection purposes, a suitable interruption device must be used to be connected to the "Fault" output.
In no case can the "Fault" output be used directly on the controlled circuit with interruption function. For protection against indirect contacts (0.03A), the interruption device to be controlled with the "Fault" output must have a max. Opening time. ≤ 0.015 s.

A "Fault" condition is always 'memorized', that is, it persists until it becomes possible to intervene on the reset mechanisms ('Reset', local or remote).

The state of failure is characterized by:

- Fault LED on steady
- Contact from the Failure relay in the Fault position (in accordance with the polarity of the desired contact, set with the 'PolarFault' parameter (a))
- Display with Fault icon flashing at the top, and at the bottom with an indication of the condition that caused the Fault with the relative non-operation time Δt passed.

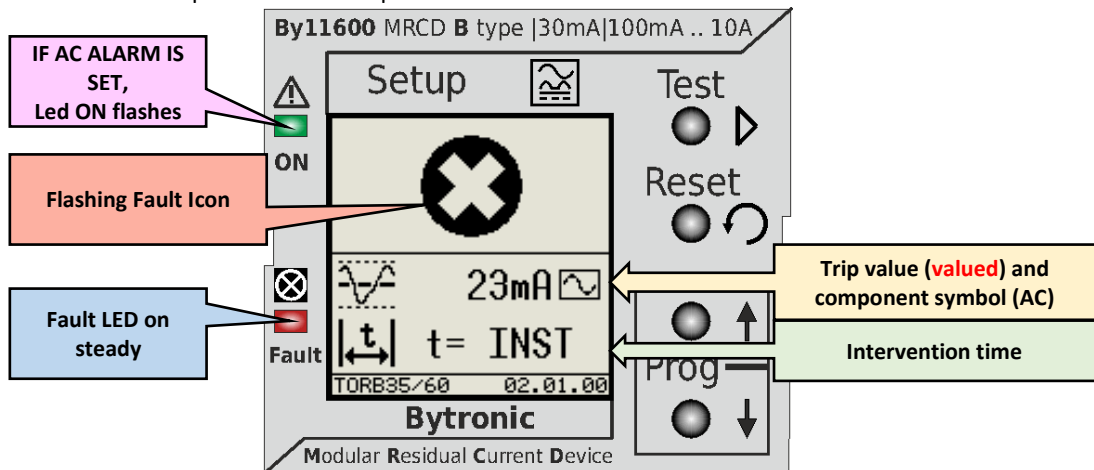

The conditions that cause the failure are:

Condition	Intervention time		Message
	$I_{\Delta n} = 0.03 \text{ A}$	$I_{\Delta n} > 0.03 \text{ A}$	
Test	INST	$> \Delta t$	-TEST EXECUTED-
Out of measure rms, ac or dc	INST	$> \Delta t$	-OUT OF RANGE-
$0,5 I_{\Delta n} < I_{\Delta ac} < I_{\Delta n} (\geq 0,75 I_{\Delta n})$	INST	$> \Delta t$	I value + AC + symbol Δt
$0,5 I_{\Delta n} < I_{\Delta rms} < I_{\Delta n} (\geq 0,85 I_{\Delta n})$	INST	$> \Delta t$	I value + RMS symbol + Δt
$0,5 I_{\Delta n} < I_{\Delta dc} < 2 I_{\Delta n} (\geq 1,5 I_{\Delta n})$	INST	$> \Delta t$	I value + DC + symbol Δt
Overload detection device	INST	$> \Delta t$	-OUT OF RANGE-
Detection device disconnected	Within 1.15s (b)		CT ERROR (Disconnected)
Short circuit detection device	Within 1.15s (b)		CT ERROR (Shorted)
Wrong detection device	Within 1.15s (b)		CT ERROR Expect TORB xxx

Note (a): The operational parameter called, 'PolarFault', is described in the section '[List of operating parameters](#)'.

Note (b): up to $\Delta t < 1s$, the intervention follows the value of Δt . For longer times, the intervention takes place within 1.15s.

When Δt is sufficiently long, on the display, on the main page, before the Fault condition becomes effective, the Fault icon is displayed between the measurements and the affected measurement (s) flashes (no).

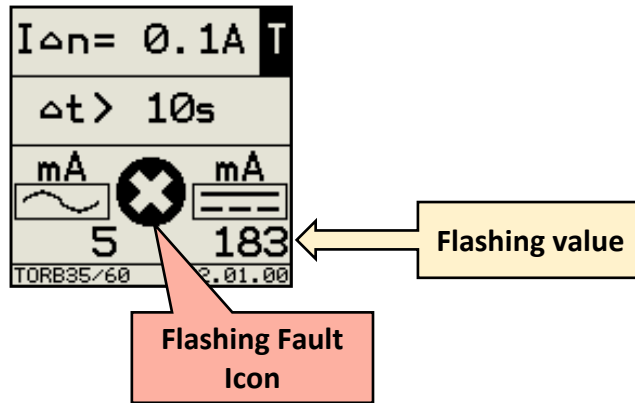

Recovery from the "Fault" condition can only take place by:

- "Reset" button
- Remote "Reset" command
- Turning the instrument off / on, removing the cause of Fault.

In the first 2 cases, Reset is possible ONLY if a negative 'R' appears in the adjacent area. See paragraph '[Reset](#)'.

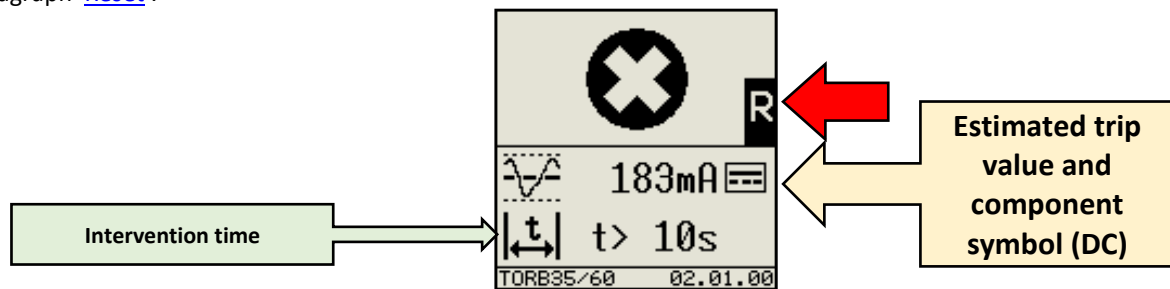

6.3.1 Intervention times

The MAXIMUM intervention times of the MRCD only, without interrupting device are as follows:

NOT DELAYED MODE ($I_{\Delta n} = 0.03 \text{ A}$)

$I_{\Delta n}$	$2 I_{\Delta n}$	$5 I_{\Delta n}$	$10 I_{\Delta n}$
0.25 s	0.13 s	0.025 s	0.025 s

As already mentioned, the interrupting device to be combined MUST have an overall opening time of $\leq 0.015 \text{ s}$.

DELAYED MODE ($I_{\Delta n} > 0.03 \text{ A}$, all ranges, from $I_{\Delta n}$ at $10 I_{\Delta n \text{ ac}}$ +/- $20 I_{\Delta n \text{ dc}}$)

Detection device	$t_{\text{max intervention}}$
TORB 35	$\Delta t + 0.15 \text{ s}$
TORB 60	
TORB 80	
TORB 110	
TORB 160	
TORB 210	

The opening time of the interruption device to be combined must be added to obtain the overall opening time.

6.4 Test execution

The test is possible in all the operating states in which the instrument is located when it is not in a Fault condition, by pressing the relative Test button (test device), which is also accessible with the front door closed (and leaded), deliberately prior use of a suitable pointed tool (pen, screwdriver, etc.) to avoid accidental maneuvers. The display area adjacent to the test button indicates a negative T when the test is possible.

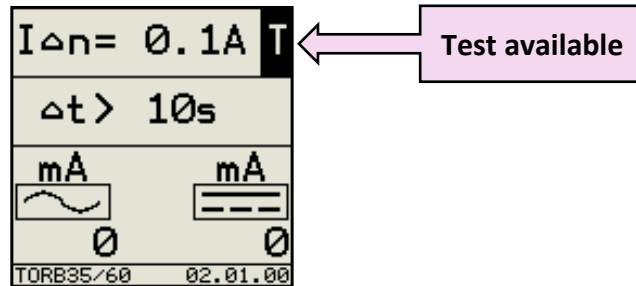

The test simulates the injection of maximum DC current to the measuring circuit. This injection of current causes an 'OVERFLOW' condition of the measurements.



The test is performed according to the duration of Δt set, then the Test button must be kept pressed for longer than Δt .

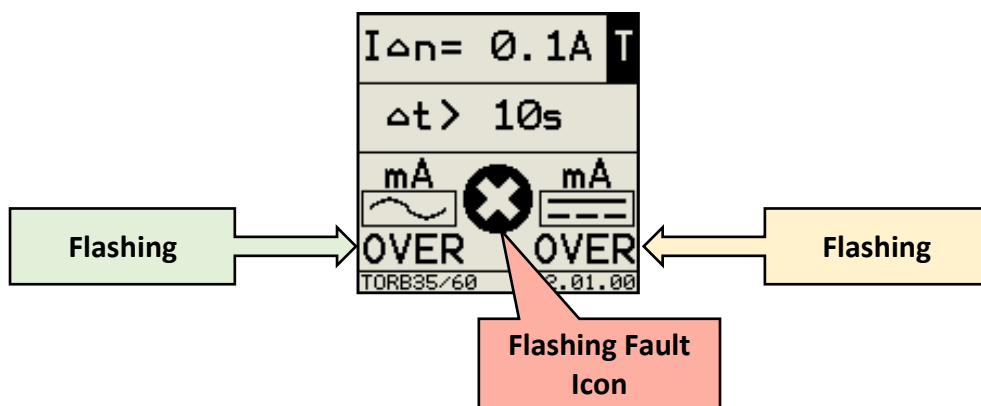

At the end, after Δt the Fault test trip will take place and, releasing the Test button, the negative R will appear in correspondence with the Reset button. See paragraph '[Reset](#)'.

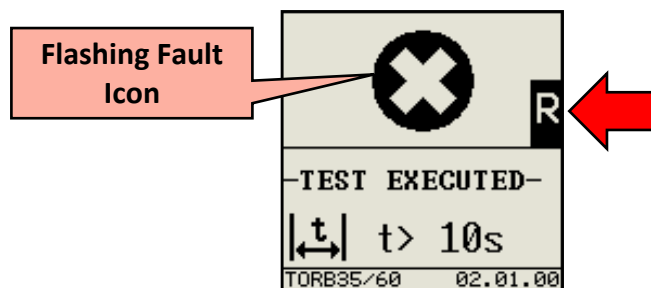

6.4.1 Effect of the Test on the Alarm output

The Test (= activation of the "Failure" output) can be performed independently of the simultaneous presence of any alarm condition and consequent active "Alarm" output.

If the Alarm output is not active, pressing the Test button has no effect on the Alarm output (the test is only performed by activating the "Failure" output).

If, on the other hand, the Alarm output is active (LED ON / Alarm flashing), the behavior changes according to whether the 'Memo Alarm' parameter is On or Off.

- If 'Memo Alarm = Off', pressing the Test button rests the output (Alarm relay goes to rest and the ON / Alarm LED stops flashing), which is reactivated if necessary, if there are any conditions. release of the Test button, in accordance with the delays set.
- If 'Memo Alarm = On', pressing the Test button does NOT put the Alarm output to rest. If in the meantime, before it is reset with the Reset command, if the current level that caused the Alarm condition has fallen below its threshold level, the Reset command will not only reset the "Failure" output, also restores that of "Alarm" by 'memorizing' also the measured values possibly acquired.

6.5 Reset

The reset from the Fault condition, "Reset", is possible only when a negative R appears on the display in the area adjacent to the Reset button.

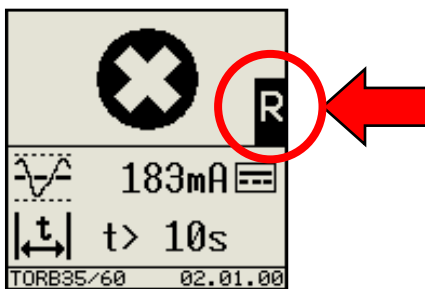

If it does not appear in the stored Fault or Alarm condition, it means that a Fault or Alarm condition is still present (not necessarily the initial one) and therefore Reset is not possible.

The reset command can only be provided manually, locally by the Reset button, or remotely by applying a voltage between 150 and 260V ac / dc to the "Remote Reset" terminals.

The reset by button is also accessible with the front door closed (labeled), but only with the use of a suitable pointed tool (pen, screwdriver, etc.) for safety reasons.

There is currently no automatic reset cycle or procedure.

7 Operation of the UP and DOWN buttons

7.1 'UP' button functions

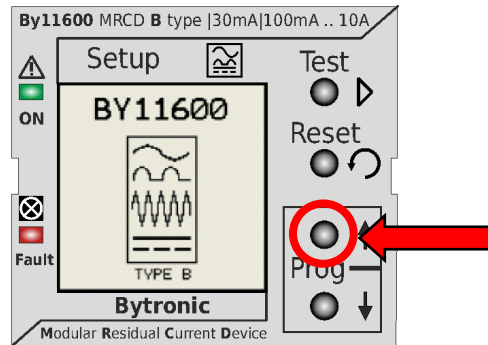

The 'UP' key has multiple functions, depending on the context of operation of the instrument.

7.1.1 *Selection of the tripping differential current ($I_{\Delta n}$)*

During normal operation, pressed once for at least 1 second but LESS than 5 seconds, increases the value of $I_{\Delta n}$, which is stored. Possible values: 0.03 A - 0.1 A - 0.3 A - 0.5 A - 1 A - 3 A - 5A - 10A, depending on the connected TORB.

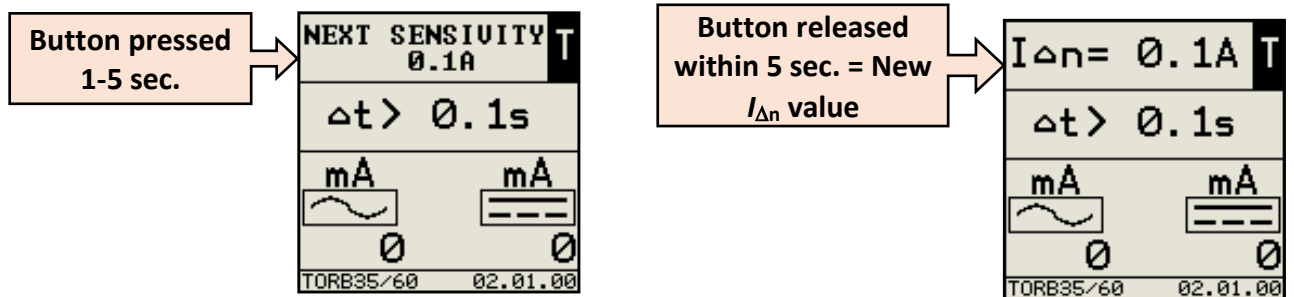

7.1.2 *Access to programming of operating parameters*

Pressed FOR MORE THAN 5 seconds, it DOES NOT change the value of $I_{\Delta n}$ but access the SETUP menu (see '[Operating parameters](#)').

7.1.3 *Regulation functions in programming the operating parameters*

In the 'SETUP' of the operating parameters, it takes on different meanings described in the chapter '[Operating parameters](#)'.

7.1.4 *Execution of the 'CT recognition procedure'*

If kept pressed before and during instrument switch-on, it allows access to the '[CT recognition procedure](#)';

7.2 Functions of the 'DOWN' key

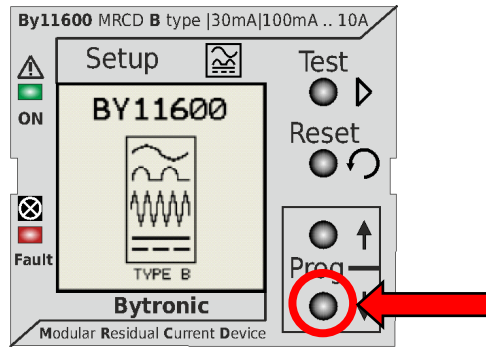

The 'DOWN' key has multiple functions, depending on the context of operation of the instrument.

7.2.1 *Selection of downtime (Δt)*

During normal operation, pressed once for at least 1 second, it increases the value of Δt , which is stored. Possible values: 0.1s-0.2s-0.3s-0.4s-0.5s-0.75s-1s-5s e10s.

Adjustment of the non-operation time is NOT allowed if $I_{\Delta n} = 0.03$ A (instantaneous mode).

7.2.2 *Regulation functions in programming the operating parameters*

In the 'SETUP' of the operating parameters, it takes on different meanings described in the chapter '[Operating parameters](#)'.

8 Operating parameters

In normal operating mode, i.e. NOT in a fault condition, pressing the 'UP' button proposes changing the scale of $I_{\Delta n}$. By holding the button down, the following screen appears after 5 seconds of pressing the 'UP' button:

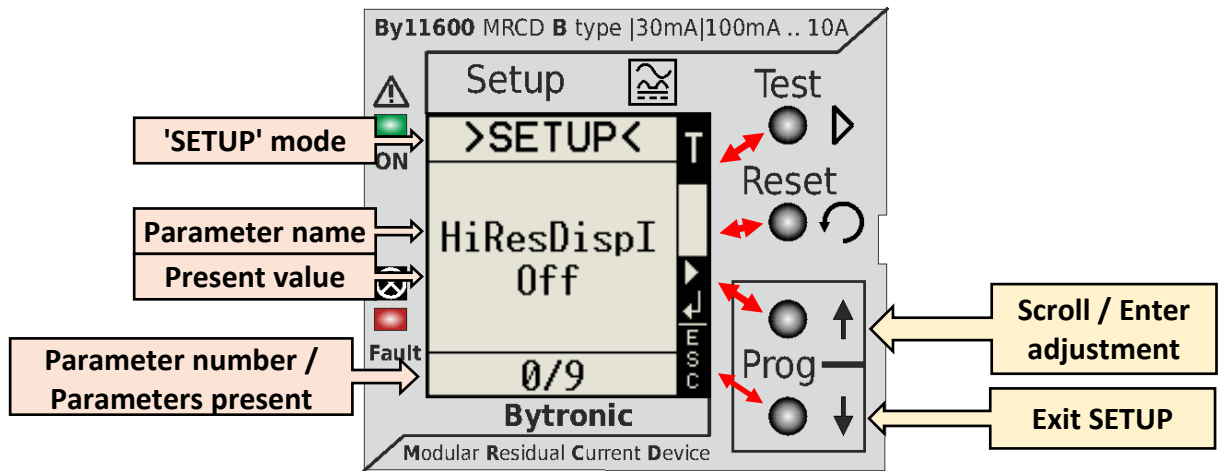

The right part of the display is related to the function of the adjacent keys, and each time in the 4 areas there are indications on the function of the relative key.

	<p>NOTE:</p> <ol style="list-style-type: none"> 1. Access to the 'SETUP' mode DOES NOT CHANGE the value of $I_{\Delta n}$ as initially proposed. 2. During the setup of the parameters, the instrument continues to function regularly and it is possible to perform both the Test and the Reset of any 'Fault' condition. If the 'Fault' condition occurs during programming, you can safely continue the parameter adjustment until you return to normal mode by pressing the "DOWN" (ESC) key. 3. As soon as one of the parameters is changed, it becomes immediately operational. the instrument immediately acquires the new value and behaves accordingly.
--	--

As soon as you enter SETUP, to start operating with the keys you must release the 'UP' key.

To scroll forward through the list of parameters, press the 'UP' button for more than 1 second and less than 5 seconds. **On release** the next parameter appears and the parameter number in the lower bar increases by 1.

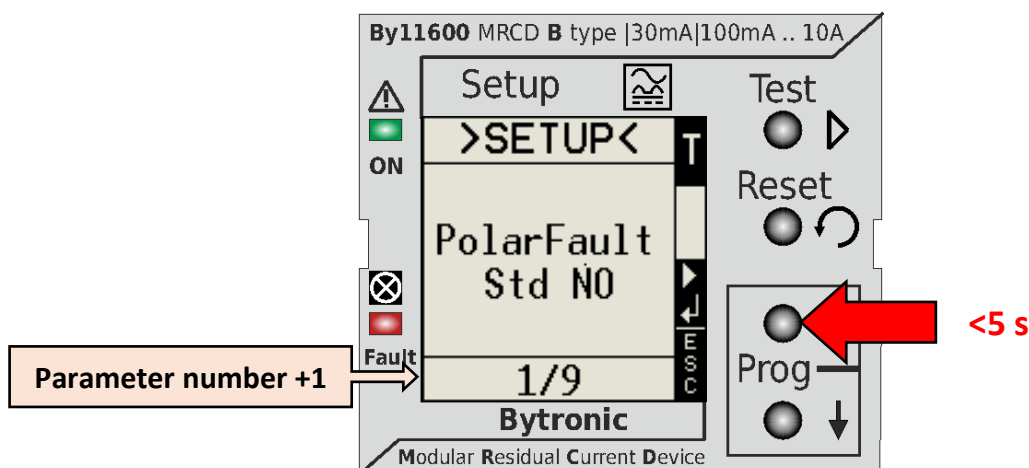

When you reach the last parameter, if you go further you go back to parameter 0.

If you want to adjust a parameter, when it is displayed, long press the 'UP' button (over 5 seconds) until the parameter name alternates between positive / negative and finally changes the screen.

The parameter name changes to the second line and the lower bar disappears.

The meaning of the 'UP' and 'DOWN' buttons changes to '+' and '-' (increases value and decreases value).

This screen is timed.

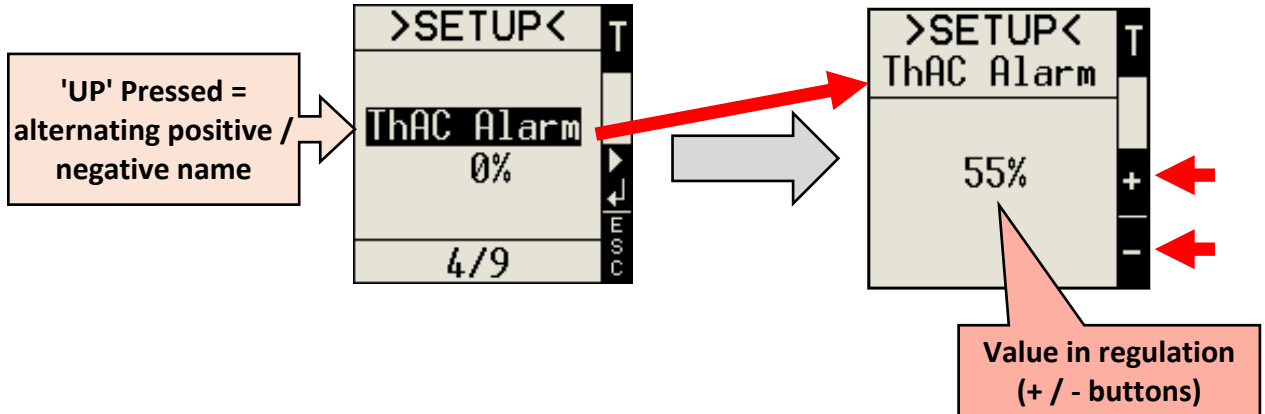

By adjusting the value to increase, the maximum value is reached and exceeded, the minimum is proposed again. Vice versa, by adjusting to decrease, once the minimum value is reached, the maximum is proposed again. Keeping the key pressed, the forward or backward will progressively faster. When the desired value has been reached, release the keys and wait.

After 4 seconds no button is pressed, the value on the display becomes immediately operational and memorized. The screen returns to the previous level showing the new value.

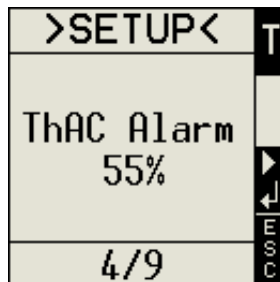

To exit programming, press the "DOWN" button

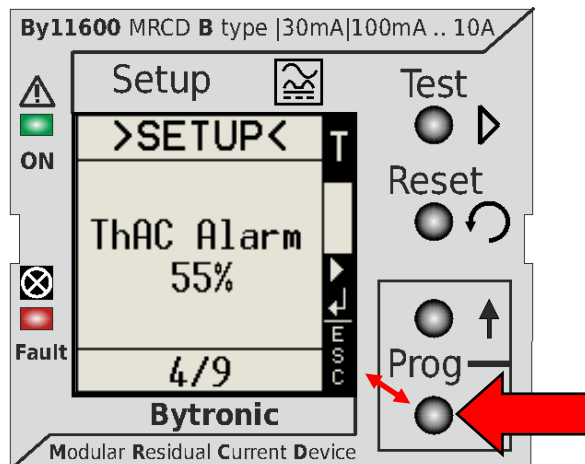

8.1 List of operating parameters

Number	Parameter name	Description	Adjustment values
0	HiResDispl	High resolution Instant display. Enable / disable tenths of mA viewing.	On - Off Factory setting: <Off> (Disabled)
1	PolarFault	Polarity relay contact "Failure" (NO = Relay energized in Fault condition)	Std NO / (+) NC Factory setting: <Std NO>
2	PolarAlarm	"Alarm" relay contact polarity (NO = Relay energized in Alarm)	Std NO / (+) NC Factory setting: <Std NO>
3	ThRMS Alarm	Threshold% Alarm $I_{\Delta rms}$	0% - 200% $I_{\Delta n}$ (0 = Excluded). Factory setting: <0% = Excluded>
4	ThAC Alarm	Threshold% Alarm $I_{\Delta ac}$	0% - 200% $I_{\Delta n}$ (0 = Excluded). Factory setting: <0% = Excluded>
5	ThDC Alarm	Threshold% Alarm $I_{\Delta dc}$	0% - 200% $I_{\Delta n}$ (0 = Excluded). Factory setting: <0% = Excluded>
6	Δt_{RMS} Alarm	Exit delay intervention Alarm for threshold $I_{\Delta rms}$	0.0 - 10.0 Sec Factory setting: <0.5Sec>
7	Δt_{AC} Alarm	Exit delay intervention Alarm for threshold $I_{\Delta ac}$	0.0 - 10.0 Sec Factory setting: <0.5Sec>
8	Δt_{DC} Alarm	Exit delay intervention Alarm for threshold $I_{\Delta dc}$	0.0 - 10.0 Sec Factory setting: <0.5Sec>
9	Memo Alarm	Storage of alarm threshold intervention.	On - Off Factory setting: <Off>

9 CT pairing procedure

This procedure is necessary (if not done in Bytronic) in the following cases:

- **Before installation.** It is necessary that the TORB combined with the MRCD is recognized correctly and that the MRCD performs a calibration to memorize the correct operating conditions. Patient until the conclusion. Larger diameter TORBs usually take longer to calibrate (1-2 minutes).
- When the CT has been replaced in the system with one of those admitted but of a different type (e.g. TORB 60 with TORB 110). At power on the MRCD would not recognize it and there would be a 'Fault' condition for "CT ERROR - Expect TORB xxx)

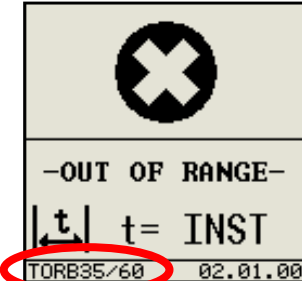
CAUTION:	<p>In particular cases the message may be different (eg -OUT OF RANGE-). Always visually check that the CT type corresponds to that recognized by the MRCD.</p> <div style="text-align: center;">  </div>
----------	---

- When the CT has been replaced with one of the same or similar type in the system (e.g. TORB 35 with TORB 60). The MRCD still recognizes it but due to constructional differences, the measurements may be distorted. The recognition procedure solves this problem.
- When in spite of ALL the prescriptions for the correct installation of the system, in the ABSOLUTE absence of current in the CT on the display, the measurements are not zero but DIFFERENTLY (max. 5-6% of the $I_{\Delta n}$). The recognition procedure can in this case solve the problem. DO NOT perform the procedure if the deviation of the measurements around zero is greater, because the problem is to be found elsewhere.

	<ul style="list-style-type: none"> • During the recognition procedure, no current (even minimum), neither load nor differential, must circulate through the CT. • THE RECOGNITION PROCEDURE MUST ALWAYS BE COMPLETED CORRECTLY. If it is interrupted before the end (for example, the device is turned off), it must be repeated completely from the beginning. Otherwise, the partial data already stored could cause the MRCD to behave unexpectedly.
---	---

Do this:

- Turn off the BY11600.
- Prepare the TA correctly connected (eg TORB 80).
NO CURRENT MUST BE CIRCULATED through it, neither of load nor differential.
- Before turning on the BY11600, press the 'UP' key and keep it pressed while turning it on. If everything is correct, the following screen appears for a few seconds:

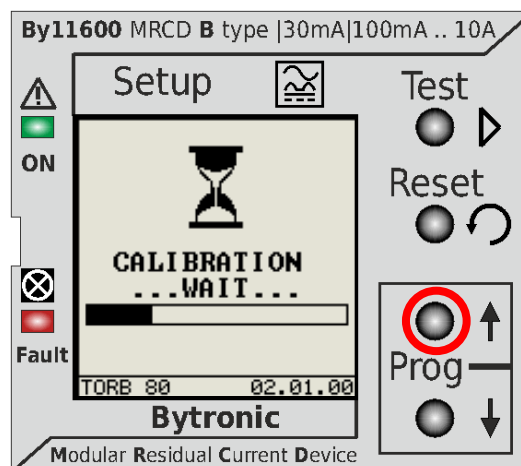

Already in this phase the type of CT is recognized (but not yet memorized).

The button can be released and wait for the end of the procedure, which is longer in proportion to the size of the TORB.

d) At the end, the Ok will be given for a few moments.

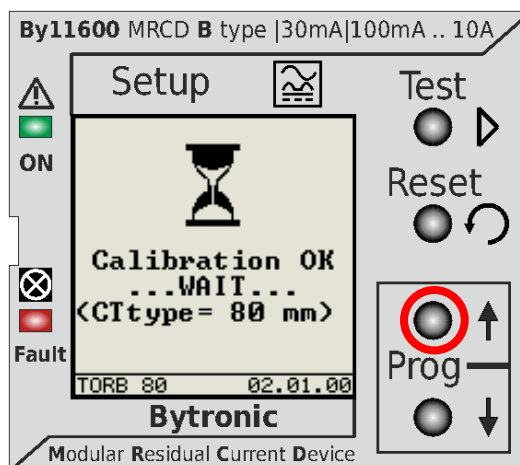



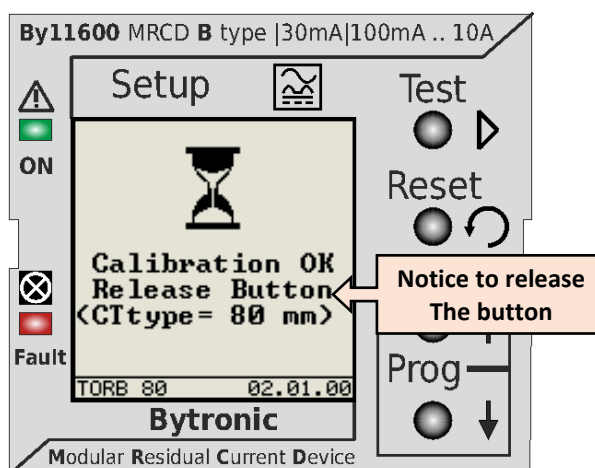

If by chance the button is still pressed at the end of the procedure, the warning is given to release it:

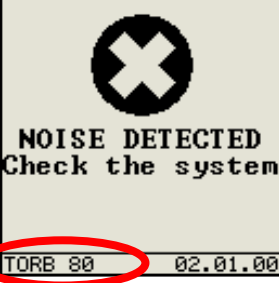

- e) After giving the warning of 'Calibration OK' (and eventually releasing the button), the instrument performs a Reset and restarts in standard mode.
 Check that at minimum flow the values are all close to zero (+/- 1mA)
- f) Wait 10-15 minutes with the instrument on, without current circulation.
 If the measurements move from the calibration value, switch off and repeat immediately from point c).

During the recognition procedure, warnings may appear about some conditions of the system which prevent the successful completion of the procedure but which DO NOT cause the Fault condition and resolve automatically as soon as they are restored.

Message	Description and solution
 <p>CT DISCONNECTED Connect it... TORB --- 02.01.00</p>	<p>The CT (Current Transformer) is disconnected. As soon as it is successfully connected, the message will be automatically removed The type of CT cannot be identified.</p>
 <p>CT SHORT-CIRCUIT Remove it. TORB --- 02.01.00</p>	<p>The CT (Current Transformer) connections are short-circuited. As soon as the short circuit is removed, the message will be automatically removed. The type of CT cannot be identified.</p>
 <p>WRONG CT TYPE Replace it. TORB --- 02.01.00</p>	<p>Type of CT (Current Transformer) not recognized (it is not TORB xxx or CT faulty). Replace it with a suitable / working type and the message will be automatically removed. The type of CT cannot be identified.</p>
 <p>NOISE DETECTED Check the system TORB 80 02.01.00</p>	<p>Too high noise signal is detected. Check connection length, interference, cable tightening, correct CT recognition, etc. The message will be automatically removed when the problem disappears. The type of CT is recognized BUT IT IS NOT STORED until the problem is solved.</p>
 <p>CURRENT DETECTED Remove it. TORB 80 02.01.00</p>	<p>Current is detected through the CT. As soon as it is reset, the message will be automatically removed. The type of CT is recognized BUT IT IS NOT STORED until the problem is solved.</p>

	<p>Always make sure that the CT is correctly identified. The attempt to recognize 'compatible' CTs (of a different brand or type), even if apparently successful, still compromises the correct functioning of the instrument. Bytronic DOES NOT GUARANTEE any functionality of the system, declining any responsibility if it is not fully realized with the indicated materials, specifically designed to meet the regulations.</p>
---	--

10 Residual current monitoring during installation or testing

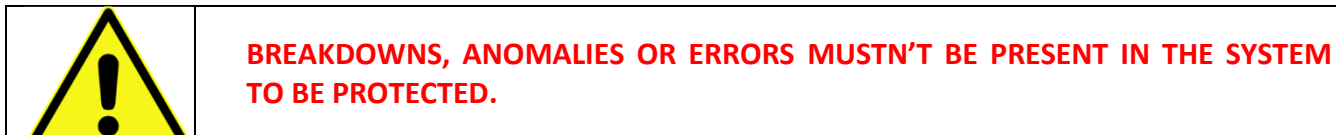

This function allows to avoid repeated disconnections of the system during the installation phase, which can create serious problems and / or long recovery times.

Having to determine the entity of the residual current characteristic of the system in steady state during the installation, testing or verification of the MRCD, before connecting the Failure output to the system interruption device, it is possible to regulate the residual current intervention, detected through the TORB sensor with the system running, **after having carefully checked that there are no anomalous conditions or real faults before switching on the system itself.**

If a too low differential current value is set, the MRCD intervenes without leaving the possibility of further adjustments until the differential current value through the TORB sensor falls below the set value, and in order to do this in the the system should turn off the loads or the system itself, which could be an undesired operation.

To unlock the 'FAULT' condition situation, force a higher differential current value proceeding as follows:

1. Press the TEST button and keep it pressed for the entire duration of the adjustment, without ever releasing it. After about 5 seconds, the main page appears on the display;
2. Still holding down the TEST button, act on the adjustments as explained in the chapter "[Operation of the UP and DOWN buttons](#)" To adjust the new current and / or delay value;
3. Release the TEST button

After releasing the TEST button, the instrument performs a Reset and resumes normal operation.

If the new differential current value set is higher than the one considered normal that is present, the 'FAULT' condition does not occur.

The installation can be terminated by connecting the MRCD 'Failure' output to the interruption device.

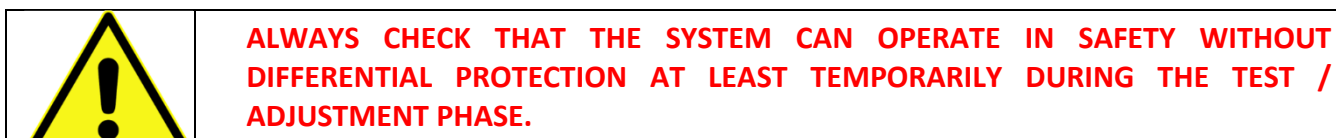

11 Technical data

Type:	Type B modular differential relay with separate detection device
Compliance:	Compliant with Italian standard CEI EN 60947-2: 2019-03 annex M. Compliant with European standard EN 60947-2: 2017-10 annex M. Compliant with international standard IEC 60947-2: 2016 / COR1: 2016 annex M
Classification:	
M.3.1.2.2	MRCD with separate detection device and processing device.
M.3.2.2.1	It intervenes automatically in the event of a power source failure, when the Failure output is programmed with positive safety (it falls in the power failure by opening the NO contact)
M.3.2.2.2	It does not intervene automatically after the fault of the voltage source but it is able to work as expected in the event of a fault with differential current, when the Failure output is programmed in standard mode (closes the NO contact in the event of a Fault)
M.3.3 - B.3.2.2	Differential switch with multiple adjustments of the rated tripping differential current with steps, with the rated value of the differential current = 10 A.
M.3.4 - B.3.3.1	MRCD without delay: non-delayed type, when it is regulated for the differential current equal to 0.03 A
M.3.4 - B.3.3.2.2	MRCD with delay: step adjustable, when it is set for the differential current greater than 0.03 A
M.3.5	The MRCD is type B according to M.4.2.2.3.
Features:	
M.4.1.1.1	The nominal frequency range of the controlled circuit is 50/60 Hz. The MRCD performs measurements up to 1 kHz.
M.4.1.1.2	The nominal voltage value U_n foreseen for the operation of the controlled circuit is 400 Vac , in TT, TNS and IT systems.
M.4.1.1.3.2	The rated current value I_n is a function of the type of detection device used: <ul style="list-style-type: none"> – TORB35 = 60 A ($I_{max} = I_{nno} = 6 I_n = 360A$) – TORB60 = 75 A ($I_{max} = I_{nno} = 6 I_n = 450A$) – TORB80 = 140 A ($I_{max} = I_{nno} = 6 I_n = 840A$) – TORB110 = 200 A ($I_{max} = I_{nno} = 6 I_n = 1200A$) – TORB160 = 275 A ($I_{max} = I_{nno} = 6 I_n = 1650A$) – TORB210 = 350 A ($I_{max} = I_{nno} = 6 I_n = 2100A$) <p><i>The intervention of the MRCD in case of failure with I beyond I_{max} is not guaranteed.</i></p> <p>In the absence of I_{Δ}, non-tripping is guaranteed for overcurrent up to $6I_n$ in the conditions of M.8.6 (See also M.4.4.3)</p>
M.4.1.1.4	The rated insulation voltage U_i with reference to the controlled circuit is 0.72 kV
M.4.1.1.5	The rated impulse withstand voltage U_{imp} with respect to the controlled circuit is 4kV (cat III)
M.4.1.2.1	The nominal value of the voltage source U_s is 230Vac. The guaranteed operating range is 0.85 U_s - 1.1 U_s (195.5 - 253 Vac)
M.4.1.2.2	The nominal value of the voltage source frequencies is 50Hz - 60Hz.
M.4.1.2.3	The rated insulation voltage U_i with reference to the voltage source is 300 V
M.4.1.2.4	The rated impulse withstand voltage U_{imp} with respect to the voltage source is 4kV (cat III)

Features (continued):**Characteristics of the "Failure" and "Alarm" auxiliary contacts (identical)**

4.6 -IEC 60947-1: 2007, IEC 60947-5 (for each contact):

- Contact: Form C (exchange)
- Device type: Relay
- Number of poles: 1
- Type of current: AC
- M.4.1.3** - Nominal voltage: 250 V
- Insulation voltage: 300 V
- Coil-contact insulation: 4kV
- Dielectric strength of contacts: 1kV
- Nominal current: 10 A
- Utilization category: AC1
- Minimum switchable load mW (V / mA): 300 (5/5)

Maximum intervention times for 'Failure' output for $I_{\Delta n} = 0.03$ A (MRCD only and only with TORB35, 60 and 80)

- M.4.2.1 - B.4.2.4.1** - $I_{\Delta} < 2I_{\Delta n} \dots \dots \dots < 0,25$ s
- $2I_{\Delta n} < I_{\Delta} < 5I_{\Delta n} \dots \dots \dots < 0,13$ s
- $I_{\Delta} \geq 5I_{\Delta n} \dots \dots \dots < 0,025$ s

To be combined with interrupting device with opening time ≤ 0.015 s**M.4.2.1 - B.4.2.4.2.1 Time limit for failure of output 'Failure' at $2I_{\Delta n}$ for the $I_{\Delta n} > 0.03$ A**Settings Δt (s): $> 0.1 \rightarrow 0.2 \rightarrow 0.3 \rightarrow 0.4 \rightarrow 0.5 \rightarrow 0.75 \rightarrow 1 \rightarrow 5 \rightarrow 10$ **M.4.2.1 - B.4.2.4.2.2 Maximum intervention times for 'Failure' output for $I_{\Delta n} > 0.03$ A (MRCD only)**For each value of $I_{\Delta ac}$ from $I_{\Delta n}$ to $10I_{\Delta n}$ and for each value of $I_{\Delta dc}$ from $\pm 2 I_{\Delta n}$ to $\pm 20 I_{\Delta n}$:

- $\Delta t + 0.03$ s $< t < \Delta t + 0.15$ s

M.4.2.2.3 This type B MRCD is suitable for operation with:

- differential sinusoidal alternating currents,
- unidirectional pulsating differential currents,
- unidirectional pulsating currents to which a leveled direct current of 6 mA is superimposed,
- differential currents that can be generated by rectifying circuits

M.4.3.3 Short-term rated current (I_{cw})
40 kA / 0.5 s**M.4.3.5 Nominal differential short-time current ($I_{\Delta w}$)**
40 kA / 0.5 s**Values of the nominal tripping differential current ($I_{\Delta n}$)**Settings $I_{\Delta n}$ (A):

- M.4.4.1** - TORB35 = 0.03 - 0.1 - 0.3 - 0.5 - 1 - 3
- TORB60 = 0.03 - 0.1 - 0.3 - 0.5 - 1 - 3
- TORB80 = 0.03 - 0.1 - 0.3 - 0.5 - 1 - 3
- TORB110 = 0.1 - 0.3 - 0.5 - 1 - 3 - 5
- TORB160 = (0.1) - 0.3 - 0.5 - 1 - 3 - 5 - 10
- TORB210 = (0.1) - 0.3 - 0.5 - 1 - 3 - 5 - 10

Minimum value of the rated non-tripping differential current ($I_{\Delta no}$)

- M.4.4.2** - For the AC component only: $0.75I_{\Delta n}$
- For the RMS component: $0.85I_{\Delta n}$
- For the DC component only: $1.5I_{\Delta n}$

Limit value of the non-tripping overcurrent in the case of a single-phase load in a multi-phase circuit ($6I_n$)

- M.4.4.3** - TORB35 = 360 A ($I_{\Delta n}$ min = 0,03 A, $I_{\Delta n}$ max = 3 A)
- TORB60 = 450 A ($I_{\Delta n}$ min = 0,03 A, $I_{\Delta n}$ max = 3 A)
- TORB80 = 840 A ($I_{\Delta n}$ min = 0,03 A, $I_{\Delta n}$ max = 3 A)
- TORB110 = 1200 A ($I_{\Delta n}$ min = 0,1 A, $I_{\Delta n}$ max = 5 A)
- TORB160 = 1650 A ($I_{\Delta n}$ min = 0,3 A, $I_{\Delta n}$ max = 10 A)
- TORB210 = 2100 A ($I_{\Delta n}$ min = 0,3 A, $I_{\Delta n}$ max = 10 A)

M.4.4.4 U_s MRCD = 230 Vac (M.4.1.2.1), 50/60Hz, 6VA ($I_{max} = 25$ mA). U_c External Reset Input: 150... 260V ac 50 / 60Hz or dc, 0.68VA ($I_{max} = 2.6$ mA)

Features (continued):	
M.6 60947-1 - 6.1.1	Ambient air temperature (normal operation): -5 ° C / + 40 ° C (average ≤ 35 ° C / 24h)
M.6 60947-1 - 6.1.2	Installation altitude: ≤ 2000 m
M.6 60947-1 - 6.1.3.1	Humidity: 5%... .. 90% (without condensation)
M.6 60947-1 - 6.1.3.2	Pollution degree: 3
M.6 60947-1 - 6.2	Conditions during transport and storage -25 ° C / + 55 ° C (+ 70 ° C <24h)
Product Specifications:	
Current measurement method:	True RMS
Precision:	± 5% FS
Housing:	Type: – Plastic 3-module DIN-EN50022 Material: – Blend PC / ABS UL94 V0 Accessories: – Sealable transparent door
IP protection degree:	IP 20
Clamps:	– Plastic body: PA - UL 94 V0 – Max current: 16 A – Max voltage: 300 V (UL) – Max cable section: ... 2.5mm ² – Max cable stripping: 7mm – Tightening torque: ... 0.5Nm
External reset circuit (see M.4.4.4):	– Typology: AC Optocoupler – Voltage at terminals (Uc):... 150 - 260V ac 50 / 60Hz or dc – Max consumption: 0.68 VA
Relay command outputs (Failure and Alarm)	See M.4.1.3
Synoptic with LED	– Red Led high brightness for 'Fault' indication – Green Led for ON indication (fixed) and 'Alarm' condition (flashing)
Keyboard	– 2 + 2 Buttons with differentiated height, F = 260gr
Graphic display	– 1.28 "Transflective ink-look type – Resolution: 128x128 pixels – Temperature: -20 ° C / + 70 ° C
Range of compatible detection devices Category III CEI EN 61869-2: 2014-05	Series "TORB" 35 - 60 - 80 - 110 -160 -210

Product functions:**'Alarm' output intervention
function
(programmable and excludable)**

Programmable 'Alarm' output polarity:

- Standard (NO closes in Alarm)
- NC (Safety, NO opens in Alarm)

Programmable current thresholds:

- RMS value: 0 - $2I_{\Delta n}$ (0 = Excluded)
- Alternating component: 0 - $2I_{\Delta n}$ (0 = Excluded)
- Continuous component: 0 - $2I_{\Delta n}$ (0 = Excluded)

Programmable intervention times:

- RMS value: 0.0 - 10.0 sec
- Direct current: 0.0 - 10.0Sec
- Direct current: 0.0 - 10.0Sec

Programmable mode of intervention:

- Automatic or Stored

Action reports:

- Call to Display
- Green LED flashing

'Alarm' output reset devices (Stored mode only):

- 'Reset' button
- Remote control in voltage 150-260Vac / dc

**Failure output intervention functions
(programmable polarity)**

Programmable 'Failure' output polarity:

- Standard (NO closes in Fault condition)
- NC (Safety, NO opens in Fault condition)

Action reports:

- Call to Display
- High brightness red led

Reset devices:

- Dedicated 'Reset' button
- 150-260V voltage remote control

Test device:

- From dedicated button, intervention after Δt

Detection device failure:

- Intervention within max 1.1 Sec (M.8.9.2, <5s)

Detection of detection device

Self-learning calibration procedure

Electromagnetic Compatibility (M.8.16) *	
Electrostatic discharge M.8.16.1.2	EN 61000-4-2
Electromagnetic fields radiated by radiofrequency M.8.16.1.3	EN 61000-4-3
Transients / fast electric transients (EFT / B) M.8.16.1.4	EN 61000-4-4
Pulses M.8.16.1.5	EN 61000-4-5
Conducted disturbances, induced by radio frequency fields (common mode) M.8.16.1.6	EN 61000-4-6
Radio frequency disturbances (150 kHz - 30 MHz) M.8.16.2 - B.8.16.2.2	EN 55016-2-1
Radiofrequency irradiated disturbances (30 MHz - 1000 MHz) M.8.16.2 - B.8.16.2.3	EN 55016-2-3
Harmonics ** M.8.16.2 - B.8.12.2.1 - J.3.1	EN 61000-3-2
Variations, interruptions and voltage dips** M.8.16.2 - B.8.12.2.1 - J.3.1	EN 61000-3-3

* Editions of the EN Standards in force in November 2019

** Additional tests

<http://www.bytronic.it/>

